

# TRC0574 - MAIN ASS'Y, P220, ULTRA LOW CGT

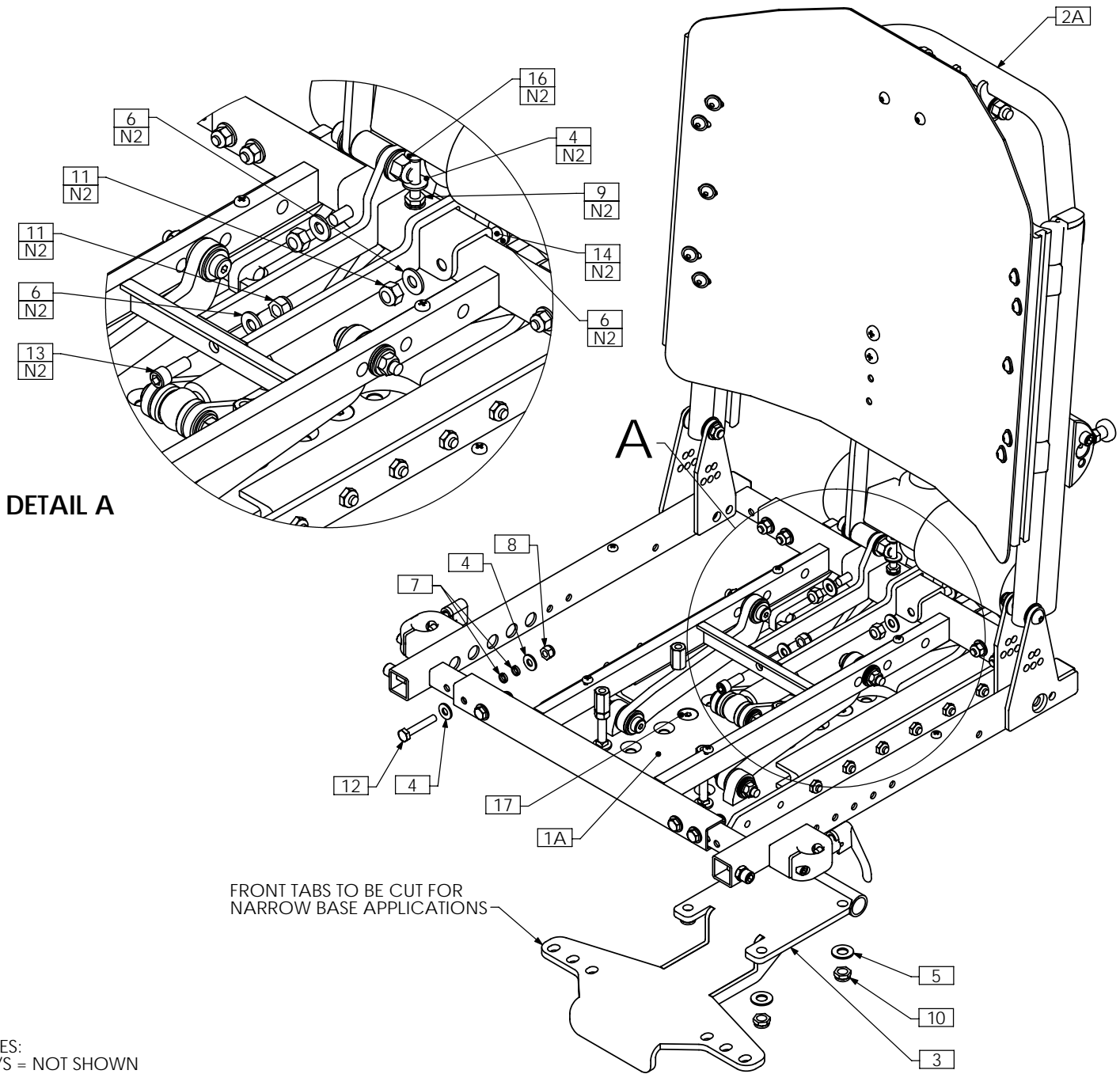

FRONT TABS TO BE CUT FOR NARROW BASE APPLICATIONS

- NOTES:  
 1. N/S = NOT SHOWN  
 2. USED ONLY FOR SYSTEM WITH RECLINE  
 3. SEAT PAN NOT SHOWN

ITEM NO.	QTY.	PART NO.	DESCRIPTION	ITEM NO.	QTY.	PART NO.	DESCRIPTION
1A	1	TRC0557	POSITIONING SYSTEM, 7" SHIFT	8	8	TRH0201	¼-20 NYLOC NUT
1B N/S	1	TRC0529	POSITIONING SYSTEM, 5" SHIFT	9	1	TRH0202	¼-20 SHALLOW NYLOC NUT
2A	1	TRC0531	UPPER SEAT ASS'Y, RECLINE AND ESR	10	4	TRH0205	3/8-16 SHALLOW NYLOC NUT
2B N/S	1	TRC0534	UPPER SEAT ASS'Y, TILT-ONLY	11	3	TRH0206	5/16-18 NYLOC NUT
2C N/S	1	TRC0530	UPPER SEAT ASS'Y, RECLINE	12	8	TRH0301	¼-20 x 1½" HEX HEAD CAP SCREW
3	1	TRX2668	MAIN SUPPORT WLD	13	1	TRH0323	5/16-18 x ¾" SOCKET HEAD CAP SCREW GR8
4	17	TRH0101	¼" FLAT WASHER	14	2	TRH0358	5/16-18 x 2" SOCKET HEAD CAP SCREW GR8
5	4	TRH0104	3/8" FLAT WASHER	16	1	TRH0377	¼-20 x 1½" FLAT SOCKET CAP SCREW
6	5	TRH0107	5/16" FLAT WASHER	17	4	TRH0442	3/8 -16 x 1" FLAT SOCKET CAP SCREW
7	16	TRH0113	¼" HI COLLAR LOCK WASHER				